



EKİN ENDÜSTRİYEL

**Water Heater Tanks, Accumulation,  
Buffer Tank Installation and  
User Manuals**



# Follow us on social media!



[www.instagram.com/ekinendustriyel](http://www.instagram.com/ekinendustriyel)



[www.facebook.com/ekinendustriyel](http://www.facebook.com/ekinendustriyel)



[www.youtube.com/ekinendustriyel](http://www.youtube.com/ekinendustriyel)



[www.linkedin.com/company/ekinendustriyel](http://www.linkedin.com/company/ekinendustriyel)



[www.twitter.com/ekinendustriyel](http://www.twitter.com/ekinendustriyel)



[www.soudcloud.com/ekinendustriyel](http://www.soudcloud.com/ekinendustriyel)



[www.spotify.com/ekin endustriyel](http://www.spotify.com/ekin endustriyel)



**The first condition of innovation is to question.  
And the first condition of sustainable innovation is to question  
constantly.**

The journey of innovation has started with a question for us too: "How can we develop value-added technologies in Turkey?". First turning point in this long journey was the birth of MIT (Made in Turkey) brand. MIT made us the first plate heat exchanger producer of Turkey and it's founding vision was not to become a local alternative, it was to build a high-quality brand that can compete on a global level.

While we are working towards this goal in the past 15 years, our products and processes deemed worthy for documentation by many national and international quality assessment institutions such as ISO, TSE, CE, GOST and many more. This was the natural outcome of our constant questioning of the status-quo and our desire to outperform ourselves.

**New Generation Engineering**

With our engineering approach that focuses on the process, not the problem, we do not just specialize in a product, we consider the entire ecosystem of that product. Ergo, we produce all the other components of a system in addition to plate heat exchangers and we focus on the constant development of engineering staff required to provide an end-to-end application.

We provide a "solution" rather than a product with our business development, presales, sales and after sales services provided by our expert engineers.

In our 15th year, we continue to grow as a solution partner for projects that need high technology in more than 60 countries with our internationally approved high-quality plate heat exchangers; components such as accumulation tanks, boilers, industrial pumps and installation materials that completes these exchangers to form a system; and complementary services provided by our expert engineer staff.



# APPLICATION FIELDS



## HEAT TRANSFER PRODUCTS

- Gasketed Plate Heat Exchangers • Brazed Heat Exchangers • Shell & Tube Heat Exchangers • Air Fan Oil Cooler • Economizers • Coils and Radiators



## PRESSURE VESSELS

- Water Heater Tanks • Water Storage Tanks • Buffer Tanks • Expansion Tanks • Stainless Steel Process Tanks • Balance Tanks / Dirt Separators / Air Separators • Vapour Separator • Pressured Air Tanks • Neutralization Tanks • Air Tubes • Steel IBC Tanks with ADR



## COMPLETE SYSTEMS UNITS

- Heat Stations • Steam Package Systems • Special Designed Systems • Dosing Systems • Substations • Thermoregulators



## FOOD GRADE SYSTEMS

- Pasteurizers with plate heat exchangers • Hygienic Pasteurizers with Shell & Tube Heat Exchangers • Cheese and Whey Systems • UHT - Sterilization Systems • CIP Systems • Hygienic Storage and Process Tanks • Homogenizers • Standardization Systems • Evaporators • Turn-key Projects



## FLUID TRANSFER PRODUCTS

- Lobe Pumps • Hygienic Centrifuge Pumps • Turbo / Roots / Centrifuge Blowers • Drum Pumps • Acid Pumps • Dosing Pumps • Monopumps • Air Operated Double Diaphragm Pumps (AODD)



## FLOW CONTROL UNITS

- Butterfly Valves • Ball Valves • Globe Valves • Knife Gate Valves • Actuators • Check Valves • Strainers • Thermoplastic Valves • Plastomatic Valves



## ENERGY SYSTEMS

- Boiler Systems • Solar Collectors • Water Heater Tanks For Solar

## CONTENTS

<b>Device Placement and Rules For Installation</b> .....	2
Control / Safety Equipments .....	2
Installation Distances by Volume .....	3
<b>Intallation Diagrams</b> .....	4
Single Serpentine Water Heater Tanks Installation Diagrams .....	4
Single Serpentine Water Heater Tanks Collector Installation Diagrams .....	5
Double Serpentine Water Heater Tanks Installation Diagrams .....	5
Electric Water Heater Tanks Installation Diagrams .....	6
Open Circuit Water Heater Tanks Installation Diagrams .....	7
Closed Circuit Water Heater Tanks Installation Diagrams .....	8
Accumulation Tank Water Heater Tanks Installation Diagrams .....	8
Accumulation Tank Collector Installation Diagrams .....	9
<b>Periodic Maintenance - Cleaning</b> .....	10
Corrosion Protection .....	11
Magnesium Anode Replacement .....	11
Magnesium Anode Life Simulation .....	12
Domestic Water Condition .....	12
<b>About Defective Products by User/ Production</b> .....	13

## IMPORTANT PRECAUTIONS



The product will be out of warranty unless the device is installed, operated and maintained as specified in the instruction manual.



Use an automatic safety valve of maximum of 8 bar with the device. Devices that do not have a safety valve in accordance with TS EN1487: 2016 or are not properly connected will not be covered by the warranty.



In order to use the device safely, your domestic water must be conditioned according to the conditions specified in the Regulation on Water for Human Consumption published in the Official Gazette dated 07.03.13 and numbered 28580 or according to World Health Organization, Guidelines for Drinking, Water Quality and other internationally accepted standards. Otherwise the device will be out of warranty.



The connection and mechanical installation of your device must be done by qualified companies according to the related product connection diagram specified in this manual.



Please make sure that the device is completely filled with water. After filling the device with water, open the hot water tap to vent.



Please check all connections and fittings for leaks.



Please make sure that the electrical connections of all MIT branded electrical products, are carried out by qualified electricians.



In the products with electrical resistance offered as an option, grounding must be done definitely by qualified electricians if the resistance is to be used.



The leakage current relay must definitely be installed on the electrical supply lines of the MIT series electric boiler products. A minimum of 6 mm grounding cable must be connected to the electrical supply panels and this cable must be installed separately from the installation with copper grounding peg or galv anized sheet in accordance with the Regulation on "Grounding in Electrical Installations".



The cable cross-sections of the power supply line for MIT branded products, are given in the tables on page 6. Always use halogen-free, TSE approved cable that provides the corresponding cable cross-section for your product.



The failures in the electrical panels, resistances and other equipment are not covered by the warranty.



The Manufacturer reserves the right to amend the product specifications, technical sizes and details and the installation designs any time without prior notice. Any information provided on this page may not be copied or used without the permission of the manufacturer. The manufacturer cannot be held responsible for technical information and diagrams.

## DEVICE PLACEMENT AND RULES FOR INSTALLATION

Please definitely let the qualified companies do the mechanical installation of your device in accordance with the product model specified in the manual pursuant to the connection scheme.

- Wooden pallets delivered for transport purposes must be removed before the assembly.
- The base where the device will be placed should be strong enough to support the weight of the device. The device must be placed on a flat surface.
- When installing the device, vacant areas should be left for the future access of the manufacturer / seller or service personnel in case of failure or for replacement purposes. Otherwise service will not be provided.
- The device must be installed in a confined space without risk of freezing. Your device is designed to operate in an ambient temperature range of +5 ° C / + 50 ° C. Devices used outside the ambient conditions and outside the specified ambient temperature are not covered by the warranty.
- The device will be out of warranty if damages arise due to inefficient operation or incorrect capacity selection and installation errors. For the efficient operation of the device, the installation should be carried out as specified in the diagram and the capacity of the heat sources (heating boiler, solar panel, electrical resistance, etc.) should be selected according to the hot water requirement.
- The device is out of warranty if the automatic type safety valve in accordance with TS EN 1487: 2016 standard is not installed, malfunctioned or not connected correctly.

### Control / Safety Equipments

Safety Equipment: The control and safety devices must be installed and operated by the user in the following order in order to prevent the domestic water temperature from exceeding 95 °C.

1. Thermostatic control device.
2. Deenergizing device.
3. Pressure reducing valve, combined pressure reducing valve and / or safety relief valve..

Safety Value	It is the valve mechanism that automatically discharges water when the limit pressure determined in pressure tanks and other systems is reached.
Expansion Tank	It is used to regulate pressure fluctuations that may occur in the system.
Filter (Strainer)	It is used to hold undesirable particulate matter that may be present in the heating fluid and domestic water.
Valve	It is used as an installation element that allows or stops water flow in the system.
Recirculation Tank	It is used to circulate the heating fluid and domestic water in the system.
Manometer	It is used to display the pressure value in the system.
Thermometer	It is used to see the temperature of the liquid in the system.
Pressure Reducer	It is used to prevent sudden increase of the water pressure.
Check Valve	It allows the liquid to flow in the system in the desired direction and prevents the liquid from flowing in the opposite direction.

The percentage of expansion and the expansion curve due to the increase in the temperature of the domestic hot water inside your device are presented in the following tables and graphs. For example, at a temperature increase of 50 °C, the volume of the water increases by 1.19%. With the increase in the temperature of the domestic water, the increasing volume is discharged with the safety equipment used in the system.

Temperature °C	Density kg/lit	Volume kg/lit	Expansion %
0	0.9998	1.0002	0
10	0.9996	1.0004	0.02
20	0.9982	1.0018	0.16
30	0.9956	1.0044	0.42
40	0.9922	1.0079	0.77
50	0.9880	1.021	1.19
60	0.9832	1.071	1.67
70	0.9777	1.0228	2.26
80	0.9718	1.0290	2.88
90	0.9635	1.0359	3.57
100	0.9583	1.0435	4.33
110	0.9519	1.0515	5.13
120	0.9431	1.0603	6.01

Water Expansion Curve by Temperature Difference

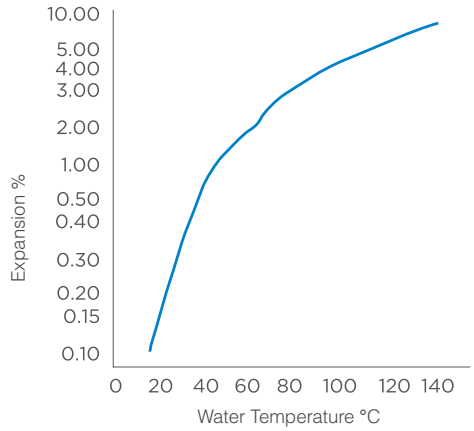

**!** For mechanical installation of the device, use automatic type maximum 8 bar safety valve in accordance with TS EN 1487: 2016 standard!

### About Expansion Tank Application

The closed expansion tank to be installed on the cold water inlet side of the device must be selected at a size of at least 10% of the device volume. Expansion tank must operate at max. 8 bar and the pre-pressure must be set 10% below the operating pressure. The pre-pressure of the expansion tank must be checked twice a year.

### Installation Distances by Volume

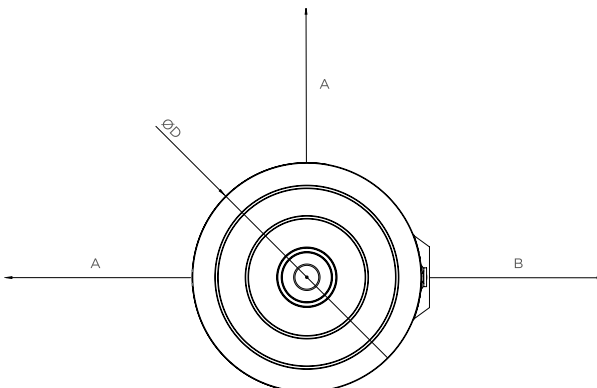



Volume   Liter	Unit	100	160	200	300	400	500
ØD	mm	490	590	590	700	750	750
A	mm	875	875	875	875	875	875
B	mm	1125	1125	1125	1125	1125	1125
Min. Ceiling Height	mm	1430±10	1475±10	1920±10	1810±10	2500±10	2850±10

Volume   Liter	Unit	800	1000	1500	2000	2500	3000
ØD	mm	900	1000	1120	1260	1460	1460
A	mm	875	875	875	875	875	875
B	mm	1125	1125	1125	1125	1125	1125
Min. Ceiling Height	mm	3150±10	3270±10	3500±10	3430±10	3400±10	3820±10

## INSTALLATION DIAGRAMS

### Single Serpentine Water Heater Tanks Installation Diagrams

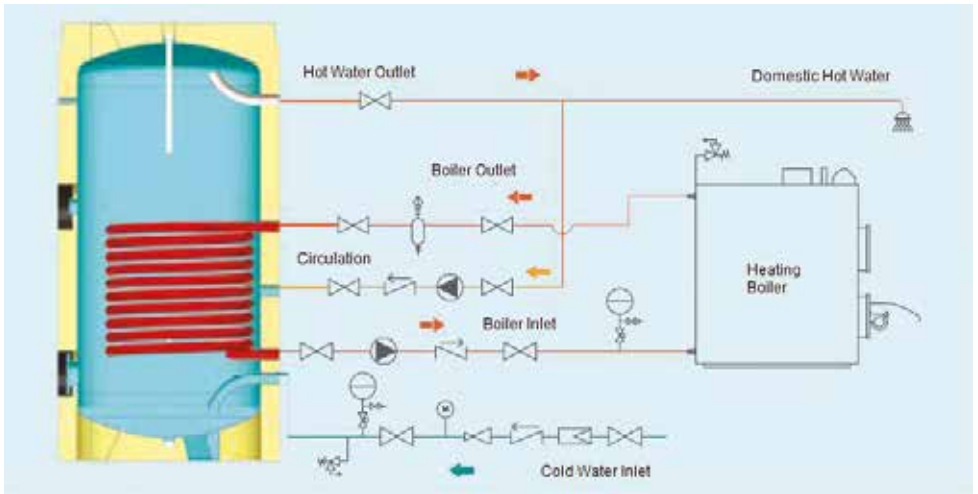

It is mandatory to use automatic safety valve up to max. 8 bar. Never use an adjustable safety valve.

## Single Serpentine Water Heater Tanks Collector Installation Diagrams

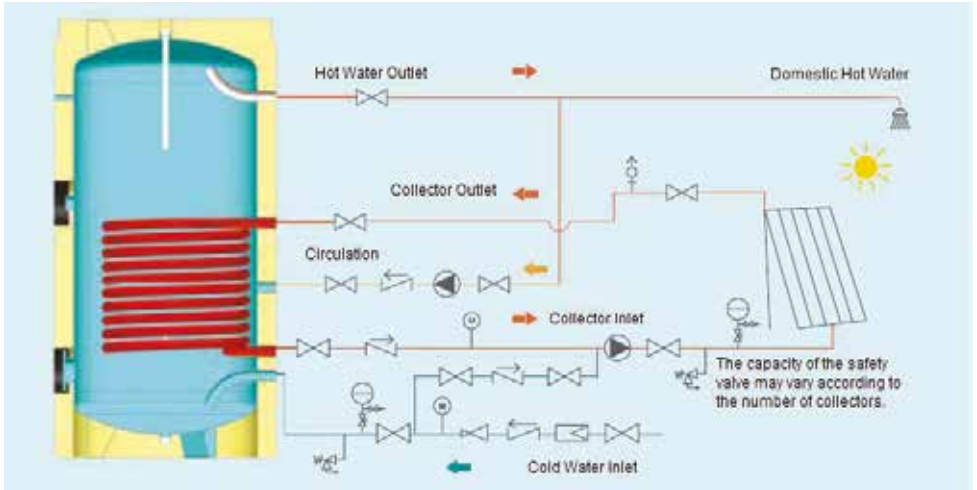

It is mandatory to use automatic safety valve up to max. 8 bar. Never use an adjustable safety valve.

## Double Serpentine Water Heater Tanks Installation Diagrams

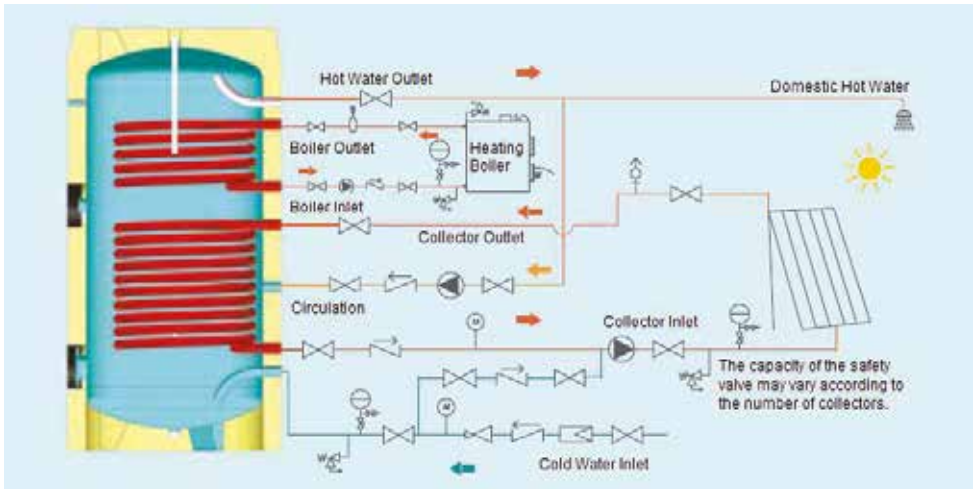

It is mandatory to use automatic safety valve up to max. 8 bar. Never use an adjustable safety valve.

## Electric Water Heater Tanks Installation Diagrams

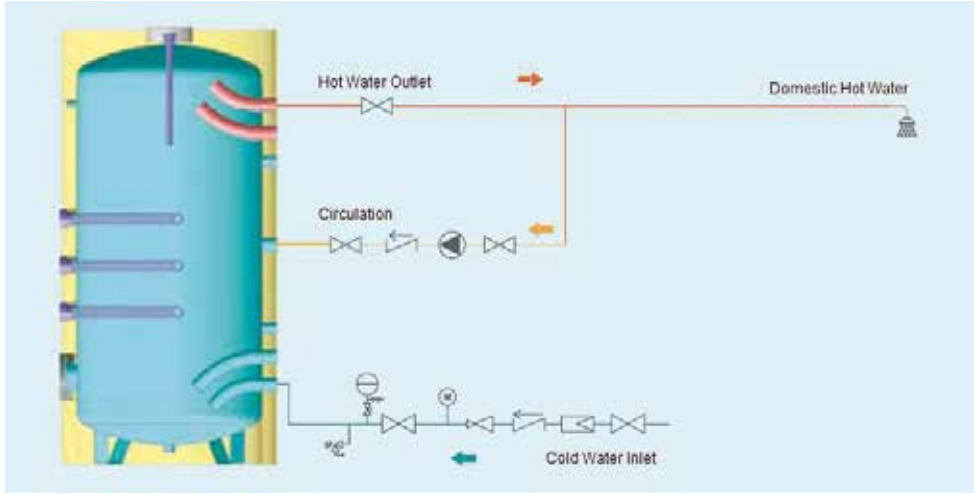

It is mandatory to use automatic safety valve up to max. 8 bar. Never use an adjustable safety valve.

## Table of Cable Cross Sections and Lengths

Panel Type	Maximum Power	Unit	Maximum Current	Unit	Cable Length <25m	Cable Length >25m
1x7,5 kW	7,5	kW	12,0	A	4x4 mm NYY	Please Consult
1x10 kW	10	kW	16,0	A	4x4 mm NYY	
1x15kW	15	kW	24,0	A	4x6mm NYY	
2x7,5 kW	15	kW	24,0	A	4x6 mm NYY	
2x10 kW	20	kW	32,0	A	4x6 mm NYY	
2x15 kW	30	kW	48,0	A	4x10 mm NYY	
3x7,5 kW	22.5	kW	36,0	A	4x6 mm NYY	
3x10 kW	30	kW	48,0	A	4x10 mm NYY	
3x15 kW	45	kW	72,1	A	4x16 mm NYY	
4x7,5 kW	30	kW	48,0	A	4x10 mm NYY	
4x10 kW	40	kW	64,0	A	4x16 mm NYY	
4x15 kW	60	kW	96,1	A	4x25 mm NYY	
>4 x .. kW	Please Consult					

## Connection of Electrical Installation

- Optional thermostat resistance operating voltage is 220 Volt AC.
- If the mains supply is 110 Volts, connect a 110/220 Volt 2000 Watt transformer.
- Replace the fuse if the amperage of the fuse in the place where you will use the boiler is less than 16 amperes.
- Connect the resistance network with at least 3x1.5 mm cable cross-section.
- The grounding line must be constructed. Otherwise, our company is not responsible for the situations that will occur.
- There must be a leakage current relay in the power supply line.

## Electrical Diagram

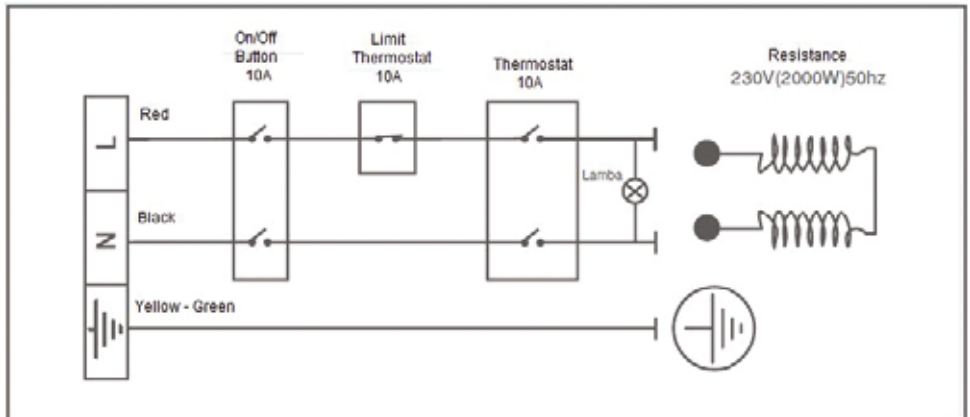

## Open Circuit Water Heater Tanks Installation Diagrams

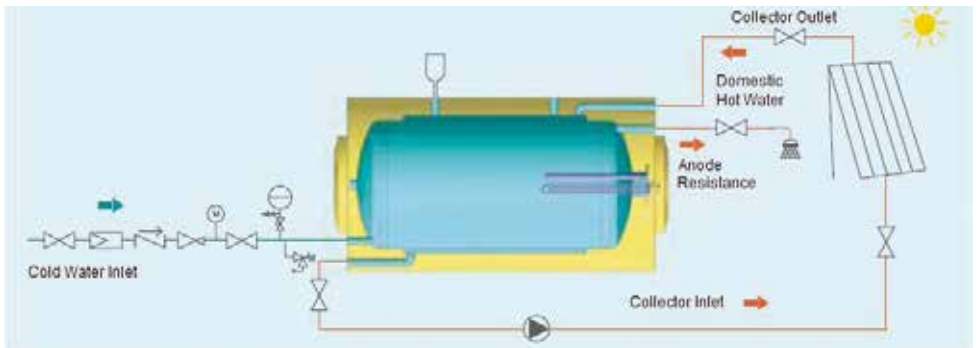

It is mandatory to use automatic safety valve up to max. 6 bar. Never use an adjustable safety valve.

## Closed Circuit Water Heater Tanks Installation Diagrams

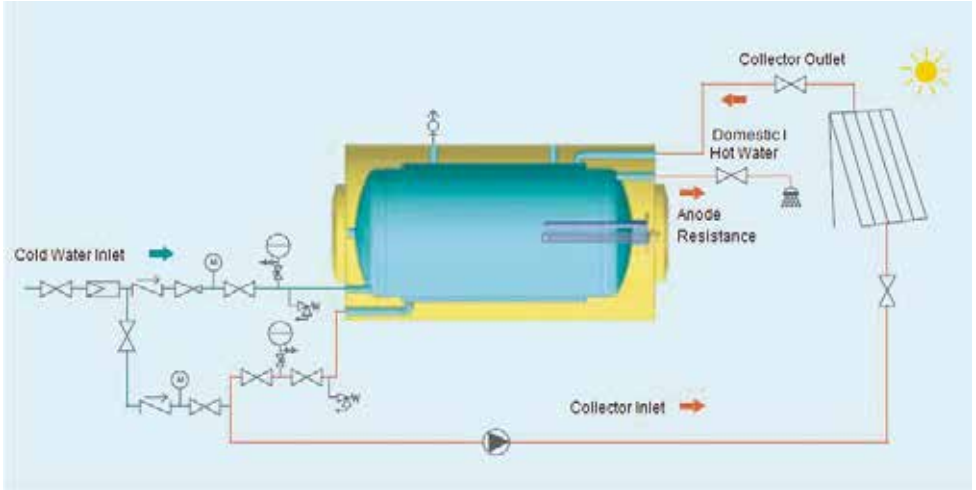

It is mandatory to use automatic safety valve up to max. 6 bar. Never use an adjustable safety valve.

## Accumulation Tank Water Heater Tanks Installation Diagrams

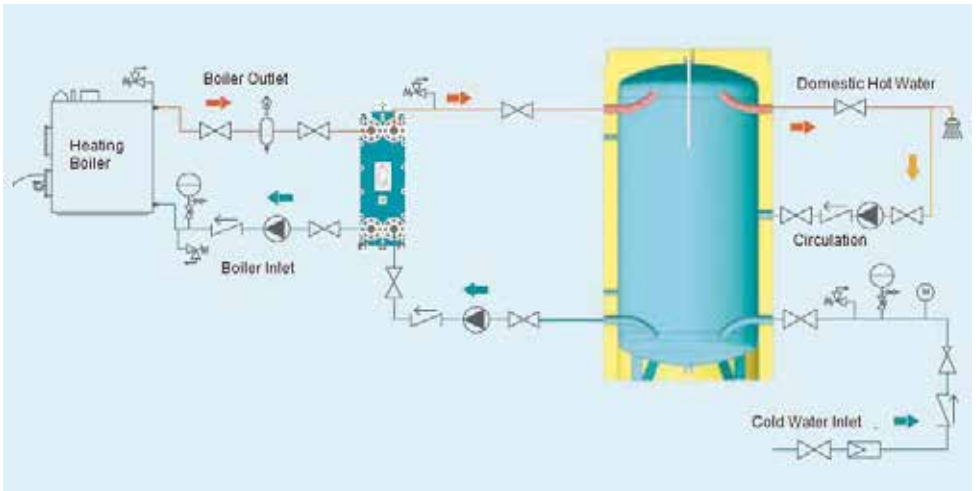





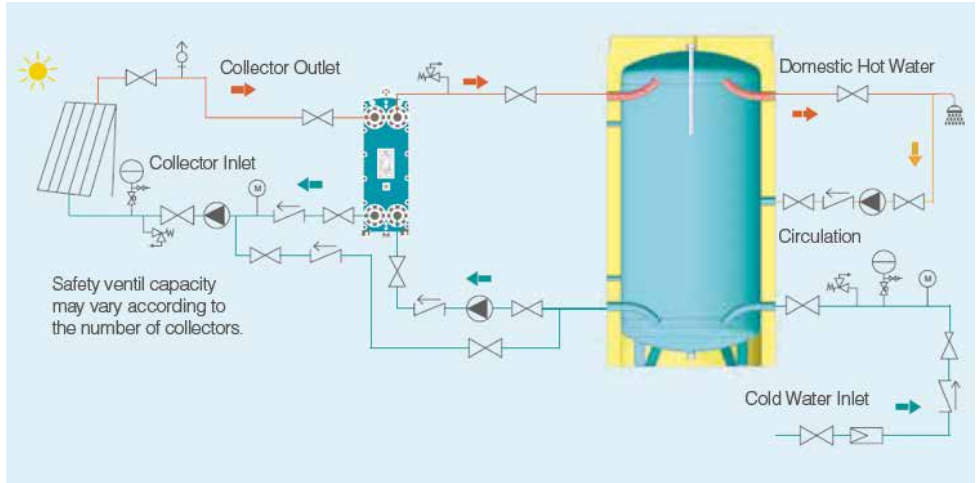







It is mandatory to use automatic safety valve up to max. 8 bar. Never use an adjustable safety valve.

## Accumulation Tank Collector Installation Diagrams



It is mandatory to use automatic safety valve up to max. 8 bar. Never use an adjustable safety valve.

## Connection Chart Icons

 Valve	 Check Valve	 Strainer	 Pressure Regulator	 Pump
 Air Purge	 Sediment Holder	 Locking Valve	 Manometer	 Expansion Tank
 Outdoor Tank	 Automatic Safety Valve	 Drain Valve		

## PERIODICAL MAINTENANCE - CLEANING



In order to get the desired performance from your device constantly, it is recommended to clean the lime, dirt and sediment, which may occur in the resistance and boiler depending on the hardness of the mains water by opening the cleaning flange periodically. Chemical cleaning is not recommended when cleaning the product.



The seals on the product, excluding the anode seals, are disposable seals. Do not reuse the seal for any reason when the parts with the gaskets are removed. Please contact the supplier.



Make sure that the equipment such as valves, check valves, strainers, safety valves, expansion tanks, thermometers in the installation of the device are intact.



Periodically remove the strainer which is installed in mechanical installation and clean the filter.



The magnesium anode on the device should be checked at least twice a year, and after the first inspection, the frequency of the inspection should be determined according to the degree of wear of the anode. Products with worn out magnesium anode are out of warranty.



When the appliance is switched off, precautions must be taken to prevent freezing and the boiler must be emptied.



When cleaning the inside of the device, do not physically and chemically damage the enamel with the inner body coating.



After cleaning the device, care must be taken that the cleaning flange, thermovil and thermostat connection points are tight.

## Corrosion Protection

Cathodic protection is the stopping of anodic reactions on the metal surface by converting metals in contact with water and air into the cathode of an electrochemical cell to be formed. The cathodic protection applied in our boilers is galvanic based and the material of galvanization is anode. The DIN 4753-3 standard offers some tolerances for enamelling. These tolerances describe traces of weak areas in the enamel coating. The task of the anode is to prevent corrosion from these areas.

The diameter and length of the magnesium anode may vary according to product model. The manufacturer has the right to choose and change the magnesium anode type to be used in the products without informing the customer.

Below are three different anode models used in the products:



PLUGGED ANODE



ISOLATED ANODE



ELECTRONIC ANODE

## When Replacing Magnesium Anode

1. Cut off cold water valve of the product.
2. Relieve the pressure in the product by opening the safety valve or the hot water tap. Never interfere with the product while it is under pressure.
3. Lift the plastic cover on the product top cover and unscrew the anode with suitable tools and equipment.
4. Identify your control periods according to the condition of the magnesium anode. The life of the anode may vary against water structure and galvanic corrosion that may or may not occur in the product. Under proper water conditions, the life of your anode is 2 years, but this period can be reduced to 6 months depending on the domestic water condition. Specify the control period not less than 2 times a year. Replace your magnesium anode according to the life simulation on page 12.
5. Assemble the magnesium anode (s) supplied in different quantity and type according to the model and volume of your product with suitable tools and household appliances.
6. Tighten the assembled magnesium anodes to the tightness requirement.
7. Open the cold water valve. You can continue to use your product.







Magnesium anode is not covered by the warranty because it is a consumable material. Electronic anodes do not require replacement. Make sure that the power supply line of your electronic anode is permanently connected to the 220V mains.



## Magnesium Anode Lifetime Simulation

When replacing your magnesium anodes, which are galvanic based cathodic protection elements, please observe the following life simulation results.

Appearance	Status	Inspection In 6 Months	Inspection In 1 Year
	%0 NOT USED	Please contact your supplier. Your anode is not active.	Please contact your supplier. Your anode is not active.
	%25 USED	You can set your control period to "ONCE A YEAR".	The conductivity of your domestic water is not suitable.
	%75 USED	You can set your control period to "TWICE A YEAR".	You can set your control period to "ONCE A YEAR".
	%100 WORN OUT	Your domestic water is not suitable for use in your boiler. Please contact the supplier.	You can set your control period to "TWICE A YEAR".
<b>NOTE: IF THE WATER IS NOT SUITABLE, PLEASE CONTACT THE COMPANY.</b>			

## Domestic Water Condition

In order to use the device safely, your domestic water must be conditioned according to the conditions specified in the Regulation on Water for Human Consumption published in the Official Gazette dated 07.03.13 and numbered 28580 or according to World Health Organization, Guidelines for Drinking, Water Quality and other internationally accepted standards. Otherwise the device will be out of warranty.

Parameters		Limit Value	Unit
Sodium	Na	200	mg/l
Ammonium	NH <sub>4</sub>	0,5	
Manga	Mn	50	
Iron	Fe	200	
Fluoride	F	1,5	
Chloride	Cl	250	
Nitrate	NO <sub>3</sub>	50	
Nitrite	NO <sub>2</sub>	0,5	
Sulfate	SO <sub>4</sub>	250	
T. Cation / T. Anion	K/A	>1	
Cadmium	Cd	5	µg/L
Chromium	Cr	50	µg/L

Parameters		Limit Value	Unit
Copper	Cu	2	µm/L
Cyanide	CN	50	µg/L
Bullet	Pb	10	µg/L
Mercury	Hg	1	µg/L
Nickel	Ni	20	µg/L
Aluminum	Al	200	µg/L
Conductivity		2500	25 °C'de µS/cm <sup>-1</sup>
pH		≤ 9,5-6,5 ≤	%mval

## ABOUT DEFECTIVE PRODUCTS BY USER/ PRODUCTION

For the products within the warranty period, the following procedure is applied in accordance with our quality standards;

1. In case of failure of your device, please contact the seller. Fill out the Customer Return and Feedback Form to be sent by the Seller and send the photo showing the mechanical and / or electrical installations to at least 1.
2. The technical service report and photographs of the defective product are recorded by the technical service personnel on the spot to pass the quality records of the customer complaint.
3. In the technical service report, the conformity of the product with the conditions specified in the user manual is absolutely evaluated.
4. During the on-site technical service, even if the location and shape of the error can be seen, the product can be called to our factory for production / user error detection.
5. If it is decided to send the new product without any destructive / non-destructive inspection results for the cases where the source of the error cannot be detected on the spot and in similar cases, the defective product should be sent to the manufacturer within 15 working days. Otherwise the product price will be invoiced to the customer. The manufacturer may wait for the results of the destructive / non-destructive testing for the time allowed by the relevant regulations.
6. The new product is shipped to the customer by the manufacturer
7. The defective product in the system is dismantled and sent to the manufacturer's factory. The product is connected to the test station in order to detect the fault / malfunction in the product. After simulating the conditions at the end user, the product is cut off and the defective / malfunction zone is removed. Technical detection is carried out with appropriate destructive and non-destructive testing techniques.

## WARRANTY CONDITIONS

Dear Customer,

1. The warranty period starts from the date of delivery and is 2 years
2. Whole of the product, including all parts are under the warranty of our company.
3. In the event that the device fails within the warranty period, the period spent in repair is added to the warranty. The repair period is maximum 20 working days. This period starts from the date of notification to the authorized service of the device or, in the absence of the authorized service, to the seller, dealer, agent, representative, importer or manufacturer of the device. It is possible for the consumer to report the failure by phone, fax, e-mail, return letter or similar. However, in case of failure to reach, the burden of proof lies with the consumer. If the malfunction of the device is not remedied within 20 working days (Sundays are not working days), the company shall allocate another product with similar characteristics to the use of the consumer until the repair begins.
4. `In case of failure of the device during the warranty period due to both material and workmanship and installation errors, repairs shall be made without any charge under labor cost, replacement part cost or any other name.
5. `The determination of the parts to be applied in the elimination of the fault, technical methods shall be determined and replaced by the company. The fault can be rectified at the location of the product or at an authorized workshop. The consumer must approve it.

6. Despite the consumer uses his/her right to repair, product exchange, refund or loss rate can be claimed during the warranty period,
  - Provided not to exceed the warranty period, in case the product fails at least four times within one year from the date of delivery to the consumer, and moreover, if such failure hinders benefitting from the product,
  - In case the consumer uses his/her right for repair, and the maximum time for repair is exceeded,
  - In case the device fails and prevents the use of the goods at least six times within the warranty period defined by the distributor, although the consumer has exercised his /her right to repair,
  - If the service station is not available by the company's service station; In case it is determined and reported that repair of the failure is not possible by seller, dealer, agent, representative, importer or manufacturer, respectively,
7. The remaining warranty period of the devices replaced with the warranty application is limited to the remaining warranty period of the purchased device.
8. The warranty does not cover any malfunctions resulting from the use of the device in violation of the instructions in this manual.
9. You can get detailed information about the features of the product you purchased 444 35 46.

## GENERAL ISSUES EXCEPT THE SCOPE OF WARRANTY

The following points and the failures, problems and damages that have arisen and / or might occur within the scope of these articles shall not be covered by the warranty.

- Distorted or lost capacity label and warranty certificate. scope of TS EN 60204-1 (switchboard). (resistance, thermostat).
- Tampering or loss of the Capacity Label and Warranty Certificate.
- Damages and malfunctions caused by improper use and not in accordance with the instruction manual.
- Damage and malfunctions caused by incorrect type selection.
- Not installing the device in accordance with the installation drawing in the operating instructions with appropriate equipment.
- Use of water that does not meet the Drinking and Potable Water Values specified in the operating instructions of the appliance.
- Low or excess voltage; the use of a hydroponic socket; Damage and malfunctions from faulty electrical wiring.
- Other electrical equipment in electrical equipment, except equipment within the scope of TS EN 60204-1 (switchboard). (resistance, thermostat).
- Damages and malfunctions caused by maintenance and repairs other than those approved by the manufacturer.
- Variable mains pressure and / or in the absence and / or failure of the automatic safety valve on the device.
- Damages and malfunctions caused by transportation, unloading, loading, storage, except physical (impact, collapse, breaking) and chemical factors after delivery of the device.
- Damages and malfunctions caused by environmental factors (earthquakes, fire, floods, floods, strong wind, lightning strikes, excessive lime / muddy / dirty water of the plumbing, moisture, humidity, dust, exposure to freezing of the device, waterless operation).





**EKIN ENDUSTRIYEL**

# CERTIFICATE OF WARRANTY



## The Document's Confirmation Date and Number:

The usage of this document has been authorized by T. C. Sanayi Bakanlığı İl Müdürlüğü in accordance with the Law No: 4077 on the Protection of Consumers and the Communiqué on the Implementation of the Guarantee Certificate put into effect based on this Law.

## WARRANTY CONDITIONS

1. Warranty period starts from the delivery date of the goods.
2. In case of malfunction of the products within the warranty period, the time spent in the repair is added to the warranty period. The repair period of the goods is maximum 30 working days. This period starts from the date of notification to the service station of the defect goods. In the absence of service station, this period starts from the date of notification to the seller, dealer, agent, representative, importer or manufacturer of the goods.
3. In case of malfunction of the goods within the warranty period due to material, workmanship or assembly defects, the goods will be repaired at no cost and no additional cost will be asked from buyer under the name of changed part price or any other name.
4. Defects caused by the use of the product contrary to the items in the user manual are out of the warranty.
5. For the problems that may arise regarding the Warranty Certificate can be applied to the Sanayi ve Ticaret Bakanlığı Tüketicihin ve Rekabetin Korunması Genel Müdürlüğü.
6. The manufacturer may request that the product be sent to its own production facility at its own discretion. The shipping cost to be spent by the customer belongs to the manufacturer; if it is evaluated within the scope of warranty as a result of the examination made on the product. If the defect is not evaluated under the warranty, all costs incurred will be invoiced to the customer.
7. The manufacturer is not responsible for any damages and losses that may occur in the cargo or warehouse during the shipment of the product.
8. The manufacturer accepts no liability for the damage caused by the following reasons:
  - Failure to comply with temperature, pressure or other conditions specified in the technical specifications.
  - Incorrect applications and normal abrasion conditions.
  - Damages that may occur from sudden opening and closing of the fluid valves.
  - Damages caused by the usage of non-original spare parts.
  - Damages that may occur during shipping.
  - Damages that may arise from corrosion.
  - Blockages caused by the fluid passed through inside the product.
  - Blockages that may arise from condensate discharge in products which are used in steam applications.
  - Damages that may occur by the blockages caused by the solid materials which can block the products.
  - Damages that may occur as a result of incorrect interventions by the un-authorized services.
  - Damages that may be caused by the lack of fixtures or not working properly.
  - Accidents and problems that may occur in the system if the safety fixtures (safety valve, thermostat, pressure sensors, temperature sensors etc.) are not used are not considered under warranty. The manufacturer is not responsible for any of the pecuniary and non-pecuniary damages that may occur.
9. Manufacturer is not responsible for secondary damages, loss of production and accidents whether it is under warranty or not.
10. All of the above items have been specified in our offer and order confirmations and you have been informed that they supersede the contract. Commissioning of the product means acceptance of the contract.

For the product that was sold to ..... LTD. ŞTİ. / A. Ş / Legal Entity on ...../...../20... with stated model, brand and serial number, all kinds of manufacturing and material defects are covered by the warranty of our company for 2 (two) years.

**SELLER**

**DEALER**

**END USER**

**Brand :** \_\_\_\_\_

**Product Type :** \_\_\_\_\_

**Product Code :** \_\_\_\_\_

**Serial No. :** \_\_\_\_\_

**Product No. :** \_\_\_\_\_

Please keep this certificate!

**NOTE:** User mistakes are not covered by warranty.  
www.eकिनendustriyel.com

## PROFESSIONAL SYSTEM SOLUTION CENTER

From our MIT professional system solution center, you can get help with your problems with your pumps, heat exchangers and your system. Our solution center consisting of expert mechanical engineers will be happy to help you.

- Domestic hot water installations.
- Central and district heating systems.
- Milk, yoghurt, heating, cooling and pasteurization systems.
- Industrial cooling and heating systems.
- Oil cooling systems.
- Energy recovery systems.
- Pool heating systems.
- Steam installations.



**+90 850 811 04 18**

It is vital for your system to be designed and implemented correctly in the first installation in order to be able to operate at the desired capacity, smoothness and long life. For this reason, you can get first-hand the technical support you need during the installation phase of your system and the problems that may arise in the business; You can reach us **24 hours +90 (216) 232 24 12 in 7 days.**

We would like to reiterate that we will be happy to share our knowledge accumulated over many years with our valued customers in order for your system to work correctly and performance. Ekin will continue to be the best solution partner for you in all applications with all kinds of heating and cooling applications.



/ekinendustriyel

**Follow us on  
social media...**





Today; **135 points** in the world.

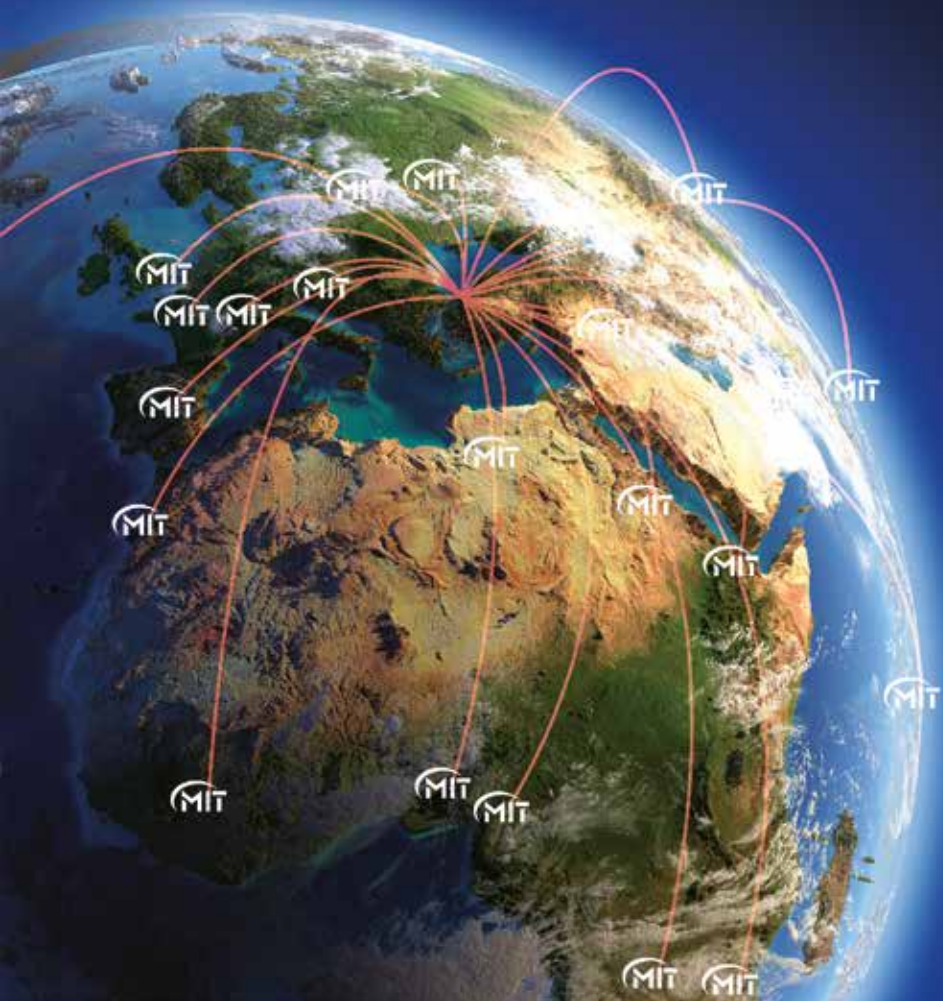

 **EKİN ENDÜSTRİYEL**  
Isıtma-Soğutma San. Tic. Ltd. Şti.

Dudullu Organize Sanayi Bölgesi - Des Sanayi Sitesi  
107. Sk. B14 Blok No: 2 Ümraniye / İstanbul / Turkey  
**Phone:** +90 216 232 24 12 **Fax:** +90 216 660 13 08  
info@ekinendustriyel.com-[www.ekinendustriyel.com](http://www.ekinendustriyel.com)

+90 216  
**444** EKİN  
3546

